

**Product Information**

**Level Transmitter /  
Switch OMNI-LC**



- Level sensor with reed chain and integrated transmitter
- Analog output, two switching outputs
- Clear, easily legible, illuminated LCD display
- Modifiable units in the display
- Designed for industrial use
- Small, compact construction
- Very simple installation

**Characteristics**

A float fitted with a magnet switches a reed chain within the guide tube; the chain is connected as a potentiometer with resistances. The resolution is 10 to 20 mm. The device has high reproducibility.

The integrated OMNI sensor electronics evaluate the potentiometer values using a microcontroller. The current level is shown in the display and output as an analog signal (0/4..20 mA or 0/2..10 V). In addition, if set limit values are fallen short of or exceeded, this can be signalled by means of two switching outputs and a red LED.

Because the complete upper part of the housing can be turned, it is possible to simply and infinitely adjust the display and the cable outlet.

By turning the programming ring to right or left, it is simple to modify the parameters (e.g. switching point, hysteresis...). To protect from unintended programming, it can be removed, turned through 180 °, and replaced, or completely removed, thus acting as a key.



**Technical data**

<b>Sensor</b>	reed switch chain with float fitted with magnet	
<b>Mechanical Connection</b>	OMNI-LC-S45HM	G 1 A
	OMNI-LC-S44HM	G 1 1/2 A
	OMNI-LC-K52HK	G 2 A
<b>For metering ranges, lengths and divisions</b>	see "Ranges, dimensions and weights"	
<b>Pressure resistance</b>	OMNI-LC-S45HM	PN 20 bar
	OMNI-LC-S44HM	PN 20 bar
	OMNI-LC-K52HK	PN 40 bar
<b>Medium temperature</b>	-20..+70 °C (with gooseneck max. 105 °C)	
<b>Ambient temperature</b>	-20..+70 °C	
<b>Storage temperature</b>	-20..+80 °C	
<b>Density of medium</b>	OMNI-LC-S45HM	<sup>3</sup> 0.34 g/cm <sup>3</sup>
	OMNI-LC-S44HM	<sup>3</sup> 0.44 g/cm <sup>3</sup>
	OMNI-LC-K52HK	<sup>3</sup> 0.66 g/cm <sup>3</sup>
<b>Voltage supply</b>	18..30 V DC	
<b>Power consumption</b>	< 1 W	
<b>Analog output</b>	0/4..20 mA, max. load 500 Ohm or 0/2..10 V	
<b>Switching output</b>	transistor output "push-pull" (resistant to short circuits and polarity reversal) I <sub>out</sub> = 100 mA max.	
<b>Hysteresis</b>	adjustable, not smaller than division, position dependent on characteristics (minimum or maximum)	
<b>Display</b>	backlit graphical LCD-Display (transreflective), extended temperature range -20..+70 °C, 32 x 16 pixels, background illumination, displays value and unit, flashing LED signal lamp with simultaneous message on the display.	
<b>Electrical connection</b>	for round plug connector M 12x1, 5-pole	
<b>Ingress protection</b>	IP 67	
<b>Materials medium-contact</b>	OMNI-LC-S45HM	CW614N and Spansil
	OMNI-LC-S44HM	CW614N and Spansil
	OMNI-LC-K52HK	stainless steel 1.4404
<b>Materials, non-medium-contact</b>	Housing	stainless steel 1.4305
	Glass	mineral glass, hardened
	Magnet	samarium-Cobalt
<b>Weights</b>	see "Ranges, dimensions and weights"	
<b>Conformity</b>	CE	

**Product Information**

**OMNI-LC**

**Wiring**

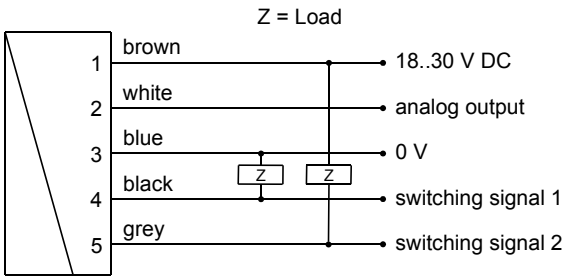

Connection example: PNP NPN

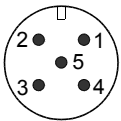

The switching outputs are self-configuring, depending on whether they are connected as PNP or NPN switches (push-pull). It is recommended to use shielded wiring.

**Dimensions and weights**

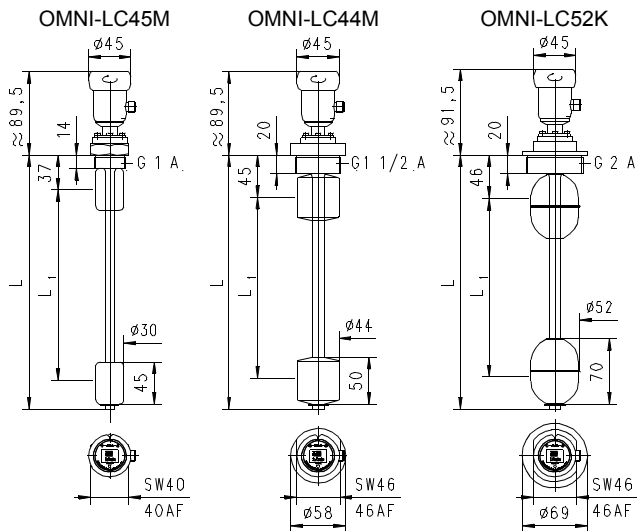

Types	Division	L	L1	Weight
OMNI-LC-	mm	mm	mm	kg
S45HM0250	10	250	190	0.6
S45HM0500		500	440	0.7
S45HM0750		750	690	0.7
S45HM1000		1000	940	0.8
S44HM1000		1000	930	0.8
S44HM1500	20	1500	1430	0.9
S44HM2000		2000	1930	0.9
K52HK0250	10	250	160	1.1
K52HK0500		500	410	1.1
K52HK0750		750	660	1.1
K52HK1000	20	1000	910	1.2
K52HK1500		1500	1410	1.2
K52HK2000		2000	1910	1.2

A gooseneck (optional) between the electronics head and the primary sensor provides freedom in the orientation and reading direction of the sensor. At the same time, this option ensures a thermal decoupling between the two units, so that media temperatures up to 105 °C become possible.

**Handling and operation**

**Note:**

Not suitable for use in media with ferritic particles.

**Installation**

Installation is carried out by screwing the sensor into a suitable threaded drilling on the upper side of the container. A flat seal is included in the scope of the delivery.

After it has been screwed in, the OMNI head can be turned to the reading direction, thanks to its free rotatability.

**Programming**

The annular gap of the programming ring can be turned to positions 1 and 2. The following actions are possible:



Set to 1 = continue (STEP)  
 Set to 2 = modify (EDIT)

Neutral position between 1 and 2

The ring can be removed to act as a key, or turned through 180 ° and replaced to create a programming protector.

Operation is by dialog with the display messages, which makes its use very simple. Starting from the normal display (currently measured value with unit), if 1 (STEP) is repeatedly selected, then the display shows the following information in this order:

**Display of the parameters, using position 1**

- Switching value S1 (switching point 1 in the selected unit)
- Switching characteristic of S1
- (MIN = monitoring of minimum value, hysteresis greater than switching value,
- MAX = monitoring of maximum value, hysteresis less than switching value)
- Hysteresis 1 (hysteresis value of S1 in the set unit)
- Switching value S2
- Switching characteristic of S2
- Hysteresis 2
- Code:  
 After entering the code 111, further parameters can be defined:
- Filter (settling time of the display and output)
- Units: e.g. l/min or m³/h
- Output: 0..20 mA or 4..20 mA
- 0/4 mA (flow rate corresponding to 0/4 mA)
- 20 mA (flow rate corresponding to 20 mA)

**Edit, using position 2**

If the currently visible parameter is to be modified:

- Turn the annular gap to position 2, so that a flashing cursor appears which displays the position which can be modified.
- By repeatedly turning to position 2, values are increased; by turning to position 1, the next digit is reached.
- Leave the parameter by turning to position 1 (until the cursor leaves the row); this accepts the modification.
- If there is no action within 30 seconds, the device returns to the normal display range without accepting the modification.

The S1 and S2 limit switches can be used to monitor minimal or

**Product Information**

**OMNI-LC**

maximal.

With a minimum-switch, falling below the limit value causes a switchover to the alarm state. Return to the normal state occurs when the limit value plus the set hysteresis is once more exceeded.

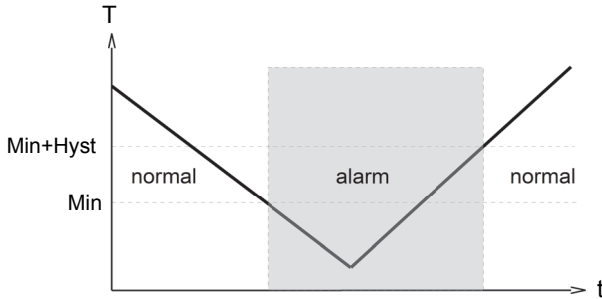

With a maximum-switch, exceeding the limit value causes a switchover to the alarm state. Return to the normal state occurs when the measured value once more falls below the limit value minus the set hysteresis.

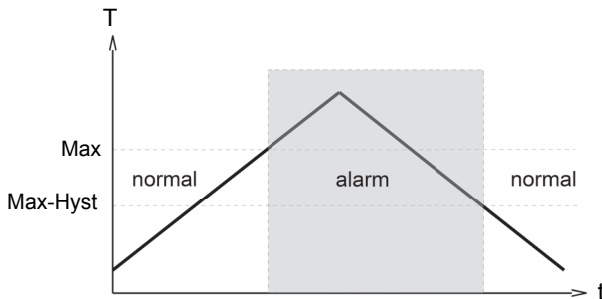

The change to the alarm state is indicated by the integrated red LED and a cleartext in the display. While in the normal state the switching outputs are at the level of the supply voltage; in the alarm state they are at 0 V, so that a wire break would also display as an alarm state at the signal receiver. Overload of the switching output is detected, indicated on the display ("Check S 1 / S 2"), and the switching output is switched off.

**Simulation mode**

To simplify commissioning, the sensor supports a simulation mode for the analog output. It is possible to create a programmable value in the range 0..26 mA at the output (without modifying the process variable). This allows the wiring run between the sensor and the downstream electronics to be tested during commissioning. This mode is accessed by means of code 311.

**Overload display**

Overload of the switching output is detected, indicated on the display, and the switching output is set to high impedance.

**Default setting**

After setting the configuration parameters, they can be reset to factory values at any time, by means of code 989.

Starting from the normal display (currently measured value with unit), if 1 (STEP) is selected repeatedly, then the display shows the following information:

**Display of the parameters, using position 1**

- Switching values S1 and S2: Switching values in the selected unit.
- Hysteresis direction of S1 and S2:  
 Max = Hysteresis less than S1 or S2  
 Max = Hysteresis greater than S1 or S2
- Hystereses Hyst1 and Hyst2:

- Hysteresis values of the switching values in the set unit
- After entering code 111, further parameters can be defined (this should take place only if necessary)
- Filter: Selectable filter constant in seconds (affects display and output)
- Unit: e.g. bar or psi ...
- Output: 0..20 mA or 4..20 mA
- 0/4 mA: Displayed value for 0/4 mA
- 20 mA: Displayed value for 20 mA

**Edit, using position 2**

- If the **visible** parameter is to be modified:
- Turn the annular gap to position 2, so that a flashing cursor appears which displays the position which can be modified. By repeatedly turning to position 2, values are increased; by turning to position 1, the next digit is reached. In this way, every digit can be modified. If there is no action within 5 seconds, the device returns to the normal display range without accepting the modification.

**Saving the changes using position 1**

- After leaving the last value, turn once to position 1; this accepts the modification.

**Ordering code**

OMNI-LC -  1.  2.  3.

○=Option

<b>1. Version</b>			
S45HM	screw-in fitting G 1 A brass - float spansil		
S44HM	screw-in fitting G 1 1/2 A brass - float spansil		
K52HK	screw-in fitting G 2 A stainless steel		
<b>2. Tube length L</b>			
0250	250 mm	●	●
0500	500 mm	●	●
0750	750 mm	●	●
1000	1000 mm	●	●
1500	1500 mm	●	●
2000	2000 mm	●	●
<b>3. Optional</b>			
H	○ model with gooseneck		

**Options**

- Tropical model (completely oil-filled for severe external applications or for rapidly changing temperatures. Reliably prevents condensation).
- Special lengths

**Accessories**

- Cable/round plug connector (KB...) see additional information "Accessories"
- Device configurator ECI-1